



ISSN: 2148-9955

International Journal of Research in Education and Science (IJRES)

www.ijres.net

Preservice Middle Grades Mathematics Teachers' Strategies for Solving Geometric Similarity Problems

Muhammet Arican¹, Oguz Koklu², Ibrahim Burak Olmez³, Serdal Baltaci¹

¹Ahi Evran University

²Marmara University

³University of Georgia

To cite this article:

Arican, M., Koklu, O., Olmez, I.B., & Baltaci, S. (2018). Preservice middle grades mathematics teachers' strategies for solving geometric similarity problems. *International Journal of Research in Education and Science (IJRES)*, 4(2), 502-516. DOI:10.21890/ijres.428297

This article may be used for research, teaching, and private study purposes.

Any substantial or systematic reproduction, redistribution, reselling, loan, sub-licensing, systematic supply, or distribution in any form to anyone is expressly forbidden.

Authors alone are responsible for the contents of their articles. The journal owns the copyright of the articles.

The publisher shall not be liable for any loss, actions, claims, proceedings, demand, or costs or damages whatsoever or howsoever caused arising directly or indirectly in connection with or arising out of the use of the research material.

Preservice Middle Grades Mathematics Teachers' Strategies for Solving Geometric Similarity Problems

Muhammet Arican, Oguz Koklu, Ibrahim Burak Olmez, Serdal Baltaci

Article Info
Article History

Received:
17 December 2017

Accepted:
16 February 2018

Keywords

Geometric similarity
Proportional relationships
Dilating perspective
Teacher education

Abstract

Proportional relationships and geometric similarity are two of the critical topics in school mathematics. Students and even teachers often struggle with recognizing the proportional relationships in geometric similarity problems. The purpose of this study was to investigate preservice middle-grades mathematics teachers' (PSTs) strategies when solving geometric similarity problems. Furthermore, we also examined the influence of the problem characteristics on the PSTs' solution strategies. The data for the present study came from 32 PSTs' responses to a geometric similarity test consisting of five problems and individual semi-structured interviews with three of these PSTs. The results revealed that the PSTs used a limited number of strategies when solving the similarity problems and usually relied on the cross-multiplication strategy in their solutions. Only a few PSTs were able to explain proportional relationships between corresponding sides of the geometric figures in the given problems. The PSTs' overreliance on the cross-multiplication strategy appeared to constrain their identification of proportional relationships. Based on the results of the present study, we propose the use of dilating perspective, a dynamic dilation-oriented method that promotes side-by-side comparison of similar figures in teaching geometric similarity.

Introduction

One of the essential goals of mathematics education is to help students make connections among mathematical ideas and use these connections for future mathematical learning (National Council of Teachers of Mathematics [NCTM], 2000). To achieve such a goal, teachers are expected to teach mathematical concepts coherently (Common Core State Standards Initiative [CCSSI], 2010) so that students can recognize and exploit diverse relationships between mathematical ideas (CCSSI, 2010; Lester et al., 1994). Geometric similarity and proportional relationships are two of the areas in which students need to understand such connections (Lee & Yim, 2014) because both areas are part of the *multiplicative conceptual field*—a web of interrelated ideas including multiplication, division, fractions, functions, and more, in addition to proportional relationships and geometric similarity (Vergnaud, 1983, 1988).

The proportion concept is one of the overarching ideas of the elementary and middle school mathematics curriculum (DeJarnette, Walczak, & Gonzáles, 2014) and is a crucial element for understanding algebra and beyond (Lesh, Post, & Behr, 1988). Similarly, geometric similarity is another essential concept of school mathematics and geometry. Although the CCSSI (2010) suggests an informal treatment of scale drawing in Grade 7 and teaching similarity in Grade 8, some studies (e.g., Lehrer, Strom, & Confrey, 2002) have demonstrated the feasibility of introducing geometric similarity at elementary grades as early as third grade. Geometric similarity can be developed through daily-life activities such as building scale models, enlarging and shrinking images, and viewing illustrations of everyday objects (e.g., Lehrer et al., 2002; Van den Brink, & Streefland, 2007). Therefore, it has a central place in school mathematics, especially when reasoning about geometry similarity. According to the Common Core Standards Writing Team (2011), students should be able to use two types of multiplicative comparisons when solving geometric similarity problems: First, they should be able to find a scale factor between corresponding sides of two similar figures and use this factor to determine the length of the missing side. Second, they should be able to form a ratio using the two lengths within one figure and to equate this ratio to the ratio formed by the corresponding lengths in the other figure by assuming the invariance of this ratio. In brief, understanding proportional relationships leads to the analysis of quantities that covary and the determination of the invariant relationship between these quantities (Lamon, 1999).

Proportional Relationships and Geometric Similarity

Despite the importance of the connections between geometric similarity and proportional relationships, a large body of research has demonstrated that geometric similarity usually poses difficulties for students. Students often cannot recognize proportional relationships in similar figures (e.g., De Bock, Verschaffel, & Janssens, 1998; Hart, 1981, 1984; Lee & Yim, 2014) and thus fail to incorporate proportionality in solving geometric similarity problems (Cox, Lo, & Mingus, 2007; Kaput & West, 1994). Instead, they usually rely on inappropriate additive relationships rather than multiplicative relationships (e.g., Kaput & West, 1994; Lobato & Ellis, 2010). Therefore, as Kaput and West (1994) claimed, geometric similarity problems are “vulnerable to additive error” (p. 275) for many students even after they have explicit mathematical instruction on these problems.

Compared to the more extensive literature on students’ understandings of proportional relationships, a small number of studies have examined preservice and in-service teachers’ reasoning about proportional relationships. The available research focusing on teachers has demonstrated that teachers may have many of the same difficulties that students hold. For instance, similar to students, teachers often resort to guessing at which operations are to be used in solving a geometric similarity problem (e.g., Harel & Behr, 1995). In addition, they experience difficulty coordinating two quantities that are in a proportional relationship (e.g., Orrill & Brown, 2012) and use additive relationships rather than multiplicative ones when reasoning about these quantities (e.g., Olmez, 2016).

Existing studies have consistently acknowledged that understanding proportional relationships is critical when reasoning on geometric similarity problems (e.g., De Bock et al., 1998; Hart, 1984; Kaput & West, 1994; Lee & Yim, 2014). For example, Lamon (1993) found that before an instruction on proportional relationships, only a few of the participated 6th grade students were able to recognize similarity in a way that proportional relationships could be applied. In a recent study with 21 middle grades students, Cox (2013) examined the type of strategies students used to scale geometric figures and the effectiveness of the shapes of several figures on students’ reasoning about similarity. Cox found that middle grades students used a variety of strategies when scaling geometric figures and concluded that visually-based strategies and more complex figures were helpful in supporting students’ understanding of similarity. Moreover, Lee and Yim (2014) investigated PSTs’ use of geometric representations when solving problems that necessitated proportional reasoning and found that PSTs’ use of representations depended on their degree of reasoning. Because geometric similarity serves as a visualization of proportional relationships, Lee and Yim (2014) concluded that it is imperative for teachers to conceptualize proportional relationships and geometric similarity as a unified concept. Therefore, investigating how PSTs identify proportional relationships when solving geometric similarity problems holds promise for making connections between proportional relationships and geometric similarity.

In this study, we investigated the PSTs’ strategies for solving similarity problems. Although a few studies (e.g., Cox, 2013) have examined the strategies of students on geometric similarity problems, past research has not yet examined the types of strategies PSTs use when solving these problems. Cox (2013) categorized middle school students’ strategies for scaling geometric figures under seven headings including Avoidance; Additive; Visual; Blending; Pattern Building; Unitizing; and Functional Scaling. On the other hand, several studies reported strategies used by students, as well as preservice and in-service teachers when solving proportion problems. For instance, Karplus, Pulos and Stage (1983b) reported students’ strategies on a scale that involved four categories: Category I (incomplete or illogical strategy); Category Q (qualitative strategy); Category A (additive strategy); and Category P (proportional strategy). Lamon (1993, p. 46) identified six strategies from 24 sixth-grade students’ responses to 40 ratio and proportion problems: Avoiding; Visual or Additive; Pattern Building; Pre-proportional Reasoning; Qualitative Proportional Reasoning; and Quantitative Proportional Reasoning.

Regarding preservice and in-service teachers’ strategies, Fisher (1988) classified secondary teachers’ solution strategies to solve two direct and two inverse proportion problems in nine categories. The first five of these categories indicated incorrect strategies, and the remaining four showed correct strategies: No Answer; Intuitive; Additive; Proportion Attempt; Incorrect Other; Proportion Formula; Proportional Reasoning; Algebra; and Correct Other. Furthermore, Arican (2018) investigated strategies used by four middle school PSTs and four high school PSTs in solving single and multiple proportions problems. Rather than classifying strategies in categories as in the studies above, he reported each single strategy used by the PSTs. Arican (2018) found that the PSTs generally relied on the following strategies more often than the others: Additive; Algebra; Proportion Formula; Ratio Table; and Unit Ratio.

In addition to the limitation of studies on examining PSTs' solution strategies on geometric similarity problems, to our knowledge, there exists no study that explains the possible effects of the problem characteristics (e.g., placement of geometric figures, numbers used, and problem contexts) on their identifications of proportional relationships when solving geometric similarity problems. It is clear that if teachers fail to recognize proportional relationships in geometric similarity problems and the relationships between proportional relationships and geometric similarity, teachers' opportunities to guide their students toward a robust understanding of proportional relationships will be limited (Lee & Yim, 2014). Therefore, the present study aimed at identifying the strategies PSTs use in solving geometric similarity problems. Furthermore, the study also examined the extent to which problem characteristics (e.g., placement of geometric figures, numbers used, and problem contexts) affect PSTs' solution strategies and determined how some of these characteristics facilitate (or constrain) the PSTs' recognitions of proportional relationships. Thus, research questions that were addressed in the present study are as follows:

1. What types of solution strategies do PSTs use when solving similarity problems?
2. How do problem characteristics influence PSTs' solution strategies and identification of proportional relationships?

Method

Participants

In the recruitment process, the purposive sampling method was used in selecting research participants. The data were collected from 32 PSTs (3 Male and 29 Female) who were attending to middle grades mathematics education program (Grades 5–8) at a public university in central Anatolia during spring 2016 semester. Except three PSTs, who were in their third year, the remaining PSTs were in their last year of the program. During the program, they took both content and methods courses on mathematics education. At the time of the study, the PSTs were contacted during a mathematics course that was taught by one of the authors. We purposefully recruited these PSTs because many of them were senior undergraduate students who were assumed to be ready for teaching geometric similarity after graduation. Similarly, since these PSTs had different instructional backgrounds and were coming from various regions of Turkey, selecting this group of PSTs enabled us to maximize the diversity relevant to our research questions.

Instrument and Data Collection

The data of this study came from the PSTs' responses to a geometric similarity test (see Appendix) that consisted of five problems. We note that the PSTs did not have any explicit instruction on proportional relationships and geometric similarity before they participated to our study. Hence, they answered five problems using their prior knowledge on these topics that they generally gained during their middle and high school years. Table 1 summarizes the characteristics of these problems by providing information such as the context and numbers used.

Table 1. Description of the test problems

Problem	Shape(s) used	Layout	Numbers used in problems
1	No shape	Not Applicable	4 by 1.5 and unknown by 7.5.
2	Two rectangles	Side by side (Traditional)	3 by 4 and 3.3 by unknown.
3	Two rectangles	Superimposing	4 by 6 and 6 by unknown.
4	Two rectangles	Dilating	27 by 36 and 30 by unknown.
5	Isosceles trapezoids	Dilating	The length of one side of the smaller trapezoid was 5 cm, and it expanded in a ratio of 2:3.

Problem 1 was a real-world problem and did not include similar figures to compare. In Problem 2, two similar rectangles were presented side-by-side as commonly found in traditional instruction. In Problem 3, one rectangle was superimposed on the second rectangle in a way that one of their corners was overlapped. In Problem 4, a rectangle was placed in the centre of a smaller but similar rectangle to indicate a dilation from the centre and respectively greater numbers were used. Finally, in Problem 5, two similar trapezoids were used,

smaller one was placed in the centre of the other, and the PSTs were provided with information that expanding the smaller trapezoid in a ratio of 2:3 yielded the larger trapezoid. Each problem included two parts: solution and explanation. In the solution part, the PSTs were asked to provide a solution to a given problem and were encouraged to provide multiple solutions. In the explanation part, they were asked to explain their solutions as if they were explaining these solutions to middle grades students in a classroom setting. The PSTs' explanations enabled us to refine the findings of this study.

The similarity test was given in a paper-pencil format during a regular classroom period. The PSTs were told that their responses to the test would be analysed for research purposes only and would not impact their grades in any way. They were given one hour to complete the test, and two of the authors were present in the classroom during the data collection process. The authors helped the PSTs by clarifying the intent by the problems and answered if they had any questions on these problems. Furthermore, in order to follow up on the PSTs' responses, the authors conducted brief semi-structured interviews with three female PSTs (i.e., Canan, Ayse, and Esma) during spring 2016 semester. The first author conducted all the interviews, and each interview took approximately 30 minutes. The interviews were video recorded and transcribed verbatim for data analysis.

The Data Analysis

The authors analysed the PSTs' responses to the problems in the geometric similarity test using the content analysis method. Two of the authors, who are experts in the field of mathematics education identified the PSTs' strategies and reasoning on the given problems. To classify the PSTs' strategies, the authors, first, familiarized themselves with the strategy frameworks described by Karplus et al. (1983b), Fisher (1988), Lamon (1993), and Arican (2018). Then, the two authors, individually, wrote descriptions of the strategies used by each PST, for every single problem.

The descriptions were then analysed as a group, until reaching consensus about the similarities and differences between particular strategies, in addition to how these strategies were applied in each problem by different PSTs. While working together, the authors constantly compared their descriptions with the PSTs' responses and revised them if necessary. As a result of this process, six distinct strategy categories were identified among the PSTs' responses to the five problems: The cross-multiplication, which included proportion formula and side-by-side entry methods, scaling-up, invariance of the expansion ratio, geometric methods, erroneous methods, and no answer or intuitive responses. These categories were discussed in the following section in details.

After deciding the strategy framework, we entered the type and frequency of strategies used by the PSTs for each problem in a Microsoft Excel sheet and calculated the cumulative results (see Table 2). Because some of the PSTs used more than one single strategy, the total of these numbers was occasionally greater than the total number of participants. In addition to identifying solution strategies, by analysing the PSTs' explanations, we also examined the extent to which they recognized proportional relationships in their responses. Moreover, in the following section, we discussed the effects of problem characteristics on the PSTs' identification of the proportional relationships.

Results

Table 2 presented the PSTs' solution strategies for the geometric similarity problems (P1-P5) and the frequency of the use of a particular strategy across the test. Based on the nature of the problems, some differences among the PSTs' strategies were observed. For instance, Problem 1 was the only problem with a real-world context, 12 PSTs preferred the scaling-up strategy and it might cue the PSTs to consider proportional relationships between quantities. On the other hand, 14 of the 32 PSTs solved Problem 5 incorrectly, suggesting that the context of this problem might be particularly difficult for the PSTs to understand. It is clear from Table 2 that the cross-multiplication was the most common strategy that the PSTs used across the problems.

Furthermore, Table 3 presented the number of strategies that the PSTs used for each problem. The name of the strategies were given in parenthesis in order that they appeared. For example, when solving Problem 1, while 21 PSTs used only one strategy, the remaining 10 PSTs used two strategies, and only one PST used three strategies. Similarly, regarding Problems 2, 3, and 4, the number of PSTs who resorted to a single strategy were 26, 27, and 25, respectively. In the last problem, all PSTs used one strategy with the highest trend of erroneous strategies.

Table 2. The preservice teachers' solution strategies

	Cross-Multiplication		Scaling -up	Invariance of the Expansion Ratio	Geometric Strategies	Erroneous Strategies	No Answer or Intuitive Responses
	<i>Proportion Formula</i>	<i>Side-by- Side Entry</i>					
P1	13	16	12	0	2	1	0
P2	24	5	4	2	3	0	0
P3	26	3	3	0	5	0	0
P4	27	3	2	4	1	2	0
P5	10	0	6	0	0	14	2
Total	100	27	27	6	11	17	2

Therefore, it is clear from Table 3 that the PSTs tended to solve the geometric similarity problems using a single strategy. In Problem 1, the number of PSTs who used more than one strategy was relatively higher than the remaining problems. This might have stemmed from the fact that this problem had a real-life context, leading to being flexible in using a variety of strategies. In addition, based on Table 3, the proportion formula strategy was the most preferred strategy among the PSTs. When they used more than one strategy, the PSTs usually tended to begin with either the proportion formula or the side-by-side entry method and used the remaining strategies as a second strategy to support their findings. A summary of these strategies with examples from the PSTs' responses were provided in the following pages.

Table 3. The number of strategies used for each problem

	Single Strategy	Two Strategies	Three Strategies	
P1	7 (Proportion formula) (Side-by-side) (Scaling-up) (Geometric)	7 6 1 1 1 1	4 (Side-by-side & Scaling-up) 3 (Side-by-side & Proportion formula) 1 (Proportion formula & Scaling-up) 1 (Geometric & Side-by-side) 1 (Side-by-side & Erroneous)	1 (Side-by-side & Scaling-up & Proportion Formula)
P2	20 (Proportion formula) 2 (Side-by-side) 2 (Scaling-up) 1 (Geometric) 1 (Invariance of the Expansion Ratio)	2 1 1 1 1	2 (Proportion formula & Geometric) 1 (Proportion formula & Side-by-side) (Proportion formula & Scaling-up) 1 (Side-by-side & Scaling-up) 1 (Side-by-side & Invariance of the Expansion Ratio)	1
P3	22 (Proportion formula) 3 (Geometric) 1 (Side-by-side) 1 (Scaling-up)	2 2 1	2 (Proportion formula & Geometric) 2 (Side-by-side & Scaling-up) 1 (Proportion formula & Proportion formula)	
P4	21 (Proportion formula) 2 (Invariance of the Expansion Ratio) 1 (Scaling-up) 1 (Erroneous)	2 1 1 1 1	2 (Proportion formula & Invariance of the Expansion Ratio) 1 (Proportion formula & Side-by-side) 1 (Proportion formula & Geometric) 1 (Proportion formula & Erroneous) 1 (Side-by-side & Scaling-up) 1 (Side-by-side & Proportion formula)	
P5	14 (Erroneous) 10 (Proportion Formula) 6 (Scaling-up) 1 (No response) 1 (Intuitive)			

The Cross-Multiplication Strategy

The cross-multiplication strategy was strikingly the most common strategy used by the PSTs, especially for Problem 2, Problem 3, and Problem 4. The PSTs using this strategy either formed a direct proportion using the given values and performed cross-multiplication or entered the given information side-by-side and then cross-multiplied these values. Therefore, in our analysis of the strategies, we decided to separate this strategy into two categories: The proportion formula method and side-by-side entry method.

The Proportion Formula Method

In the proportion formula method, the PSTs formed a direct proportion either by comparing the given sides or by using one of the geometric similarity theorems, such as Thales' theorem. For instance, Canan (all student names were replaced with pseudonyms in this study) initially solved Problem 3 forming a proportion comparing corresponding sides in two rectangles. Next, she used Thales' theorem as a second strategy (Figure 1). When the interviewer asked Canan to explain her strategies, she responded as follows:

Canan: When I read the given problem, my first intuition was to figure out the ratio of short side to short side and the ratio of long side to long side in given rectangles. I considered rectangles of AFGH and ABCD. In the rectangle AFGH, I first wrote the ratio of 4 to 6 by considering the ratio of short side to long side. Then, I equated this ratio to another ratio of 6 to x by focusing on long sides. As another solution way, I drew the diagonal of AC and recognized the right triangle of ACD. Then, I applied Thales theorem to the problem by considering the ratio of AH to AD and HG to DC, which is equal to 4 to 6 and 6 to x. That's how I solved the problem using similarity.

It should be noted that regarding the PSTs who used the proportion formula method, most of them formed a direct proportion comparing corresponding sides in two similar rectangles. Only a small number of PSTs recognized the Thales' theorem. Furthermore, some PSTs formed a direct proportion comparing sides within figures, but most of them preferred comparing sides between figures. In addition, although the ratio of $\frac{4}{6}$ (see Figure 1) formed by the lengths of the corresponding sides was a scale factor between these two rectangles, only a few PSTs were able to explain this relationship. In brief, the PSTs usually performed the proportion formula method without considering the proportional relationships presented in those problems.

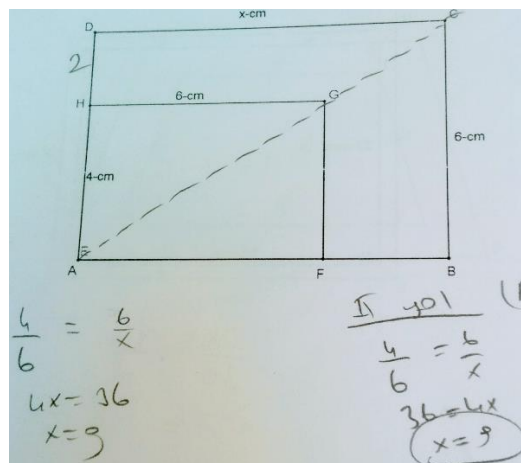

Figure 1. Comparison of corresponding sides and Thales' theorem in Problem 3

Side-by-Side Entry Method

In the side-by-side entry method, the PSTs entered the given information side-by-side and then cross-multiplied the values. As shown in Table 2, the PSTs mostly preferred to use this strategy to solve Problem 1. It appeared that because Problem 1 had a real-world context and did not include two similar figures to compare, the PSTs entered the given information side-by-side and then cross-multiplied the provided values. The only difference between the proportion formula and side-by-side entry methods was that the PSTs formed a proportion in the proportion formula method but not in the side-by-side entry method. We did not notice a difference between these two methods in terms of their contributions to the PSTs' understandings of the proportional relationships

between sides. For example, Ayse solved Problem 1 using the side-by-side entry method (Figure 2). During the interview, she used the proportion formula strategy to explain the reason behind her side-by-side entry method. This result suggested that many of the PSTs were using the proportion formula and side-by-side entry methods interchangeably. In addition, Ayse also noted that forming a direct proportion by either comparing heights in between figures ($\frac{4\text{ m}}{x\text{ m}} = \frac{1.5\text{ m}}{7.5\text{ m}}$) or within figures ($\frac{4\text{ m}}{1.5\text{ m}} = \frac{x\text{ m}}{7.5\text{ m}}$) would have yielded the same results.

Figure 2. Side-by-side entry method

The Scaling-up Strategy

In the scaling-up strategy, the PSTs calculated a scale factor between two similar figures and explained this factor as the multiplicative relationship between the corresponding sides in their solutions. For instance, to solve Problem 1, as a second solution strategy, a PST determined the apartment's shadow to be 5 times that of the tree. Hence, the PST calculated the height of the apartment as 20 cm, which should be 20 meters, by iterating the height of the tree 5 times (Figure 3). In a similar fashion, in Problem 4, another PST determined the scale factor between 27 mm and 30 mm as $\frac{10}{9}$. Next, multiplying 36 mm by this scale factor, the PST correctly determined the length of the missing side to be 40 mm. In his solution, the PST wrote "Because two rectangles are similar, the short side of the rectangle in the centre is 27 [mm] and the short side of the rectangle in the outside is 30 [mm]. Hence, I can find that the rectangle in the outside is $\frac{10}{9}$ times the rectangle in the centre. Therefore, $x = \frac{10}{9} * 36 = 40$ mm is the solution."

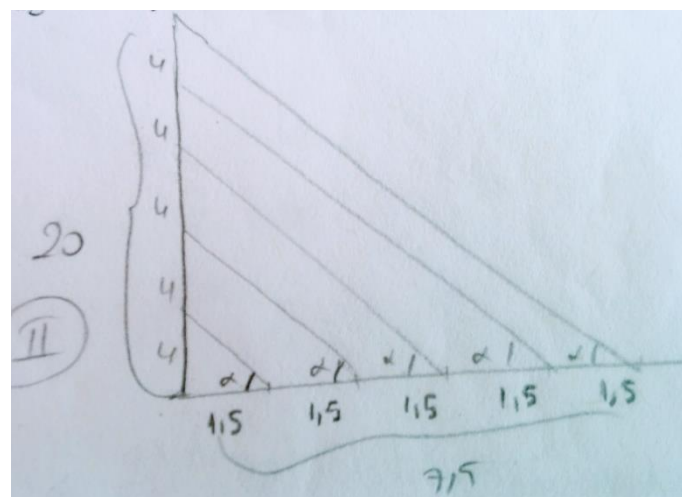

Figure 3. The scaling-up strategy in Problem 1

Similar to these two PSTs, Esma solved Problem 1 by considering the proportional relationships between the heights of the shadows of the tree and apartment. In her solution, she wrote that 7.5 cm was 5 times 1.5 cm, and so the height of the apartment was also 5 times the height of the tree. On the other hand, she used the proportion formula method to solve Problem 2. During the interview, the interviewer asked her if she could use the scaling-up strategy to solve this problem as she did for Problem 1. She responded as follows:

Esma: While short side of ABCD rectangle is 3 cm, it is 3.3 cm in EFGH rectangle. That is, it's increased by 1.1 times. Therefore, the long side of EFGH rectangle must be 1.1 times as the long side of ABCD rectangle, which is 4. Hence, the answer should be 4.4.

Her use of the word “times” indicated that she was able to recognize proportional relationships between the corresponding sides of two similar rectangles. However, the data did not give further information about why she initially used the scale-up strategy in Problem 1 but not in Problem 2. It is possible that the PSTs’ strategy preferences may have been influenced by the contexts and numbers involved in the given problems. Because Problem 1 involved a real-world context and recognizing the multiplicative relationships between numbers was easier than recognizing the multiplicative relationships in Problem 2, a tendency towards reasoning about proportional relationships among some of the PSTs was observed.

The PSTs who used the scaling-up strategy considered the proportional relationships between the corresponding sides of two similar figures. Of these PSTs who focused on the scale factor between two figures, only a few of them were able to recognize the invariance of the similarity ratio formed by comparing the lengths of the sides within a figure. As shown in Table 2, 12 PSTs used the scaling-up strategy to solve Problem 1. This result suggests that using a real-world context in problems may facilitate PSTs’ recognition of the proportional relationships.

Invariance of the Expansion Ratio Strategy

In this strategy, the PSTs solved problems considering the invariance of the expansion ratio. For example, in Problem 4, a PST wrote that “Increasing 27 cm [the unit needed to be mm] by one-ninth would give us 30 cm. Hence, increasing 36 cm by one-ninth, it would increase by $36 * \frac{1}{9} = 4$ cm. Therefore, the length of the missing side is $36 + 4 = 40$ cm.” Only a few of the PSTs used this strategy. Because the focus was on the additive differences (e.g., $30 \text{ mm} - 27 \text{ mm} = 3 \text{ mm}$, which is one-ninth of 27 mm), this strategy appeared to be ineffective in explaining proportional relationships between the sides.

Geometric Strategies

In a few instances, the PSTs explicitly mentioned geometric theorems when solving the given problems. To solve Problem 3, as a second solution strategy, a PST moved the small rectangle next to the big rectangle, taking advantage of the equality of the lengths of long side of the small rectangle and the small side of the big rectangle (Figure 4a). Next, the PST formed a right triangle by drawing the diagonals of these two rectangles and then calculated the missing side using the properties of this right triangle. Similarly, Canan correctly calculated the length of the missing side in Problem 2 as 4.4 cm, considering the equality of the tangents in two similar rectangles (Figure 4b). During the interview, she explained her solution as follows:

Canan: In this case, I thought as follows: First, I drew BD line segment. Then, I drew EG line segment. Because these two triangles [refers to ABD and EFG triangles] are similar, I thought that I can find the answer by finding tangent value. That is, their tangent values are equal.

INT: What is the reason that makes you think that way?

Canan: Because the only change would be on their ratios. For example, I can consider 3 to 4 or 6 to 8. Or, I can take 9 to 12 as three times of 3. Their tangent values are always equal because they are similar, with same ratios.

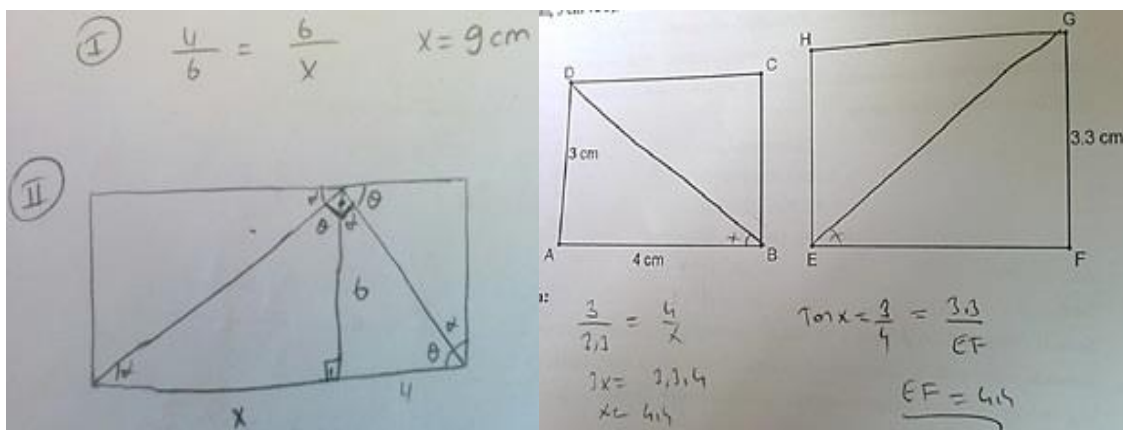

Figure 4. (a) Using properties of a right triangle in Problem 3; (b) The use of tangents in Problem 2

As can be understood from her response, after recognizing ABD and EFG were similar triangles, Canan was able to use the equity of the tangents to calculate the length of the missing side. Figure 4b showed how she used this method as a second strategy. This result suggested that PSTs may rely on the well-known strategies (i.e., proportion formula and cross-multiplication) as their first choice when solving geometric similarity problems. However, when they are encouraged to use multiple solution methods, they may employ other less commonly used strategies.

Erroneous Strategies

Fourteen of the 32 PSTs incorrectly solved Problem 5. The common issue across these incorrect solutions was multiplying the top side of the small trapezoid by 2 and the bottom side by 3 (see Figure 5). This mistake suggested that the PSTs were not able to understand what the lengths of two similar isosceles trapezoids being in a fixed 2:3 ratio implied. For example, during the interview with Canan, the interviewer asked her to explain what she understood by the small and large trapezoids being in a fixed 2:3 ratio. She responded as follows:

Canan: Based on the problem, the ratio of DC to AB is already given as 3/5. It seems that the big trapezoid is the extended version of the small trapezoid, and the sides of the trapezoids are parallel. Then, I knew that this is 3 [points at to DC side], this is 5 [points at to AB side], and if I multiply these sides with 2/3, then I will have the extended trapezoid. I am, in fact, extending the small trapezoid into the big trapezoid, not changing it.

INT: Do you consider 2 to 3 as extending the trapezoid in a ratio of 2/3?

Canan: Yes, exactly.

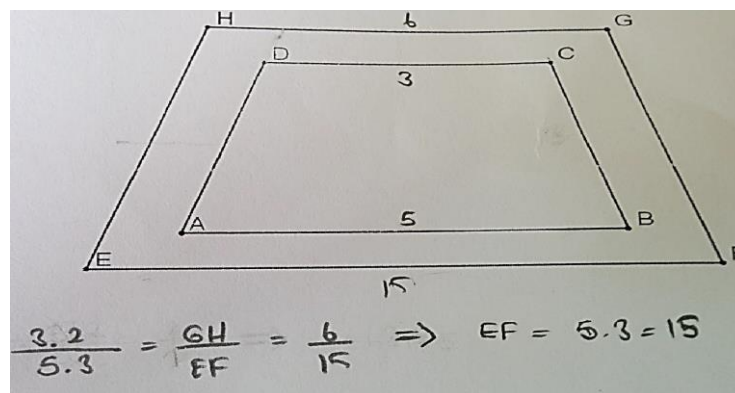

Figure 5. An erroneous strategy in Problem 5

Ayse and Esma solved this problem incorrectly using a type of reasoning that was very similar to Canan's. During the interview, Ayse explained her reasoning as follows: "If it is extended in a ratio of 2 to 3, the length of short side of the trapezoid should be twice as 3 cm. That is, 3 times 2, it should be 6. Its length of long side should be three times as 5 cm."

Similarly, Esma explained her understanding of expanding ABCD trapezoid in a ratio of 2 to 3 by the following statement: "Expanding ABCD trapezoid by a ratio of 2 to 3 means that short side is expanded by 2, and long side is expanded by 3." Canan, Ayse and Esma's responses suggested that they did not understand what was implied by expanding ABCD trapezoid by a ratio of 2:3. Their common mistake was that they thought the length of the small side was expanded by 2 and the length of the long side was expanded by 3. Possible explanations for this type of mistake could be that they might be unfamiliar with this kind of problem context or they might lack how to use the information given in the form of "a fixed 2:3 ratio".

During the interview with Canan, she multiplied 3 cm by 2 and 5 cm by 3 and calculated the lengths of the small and long sides of EFGH trapezoid as 6 cm and 15 cm. Next, she explained that the ratio between 6 cm and 15 cm should also be 3 to 5. When the interviewer asked her if the ratio formed by 6 cm and 15 cm would be equal to 3 to 5 ratio, she divided 6 cm by 15 cm and got a 2 to 5 ratio. Therefore, she recognized that her solution was inappropriate. Later, she stated that rather than multiplying short and long sides by 2 and 3, respectively, she might have multiplied both 3 cm and 5 cm by $\frac{2}{3}$. When she multiplied 3 cm by $\frac{2}{3}$, she got 2 cm and recognized that multiplying both sides by $\frac{2}{3}$ was shrinking the ABCD trapezoid. Hence, she recognized that her new understanding of "2:3 ratio" was also incorrect. Although she understood that the ratio between the lengths of

the small and long sides of the EFGH trapezoid was also 3 to 5, she could not see that multiplying both short and long sides by $\frac{3}{2}$ would have yielded the correct solution.

Analysis of the Preservice Teachers' Explanations

In addition to identifying the PSTs' solution strategies when solving geometric similarity problems, they were also asked to provide explanations for their solutions. As shown in Table 4, only a few PSTs attended to the proportional relationships in their explanations. The problem in which the PSTs mostly attended to proportional relationships was Problem 1. Among the 11 PSTs, who attended to the proportional relationships in their explanations, seven of them used the scaling-up strategy, two used side-by-side entry, one used proportion formula, and one calculated an incorrect solution by mistakenly calculating 7.5 meters being 3 times 1.5 meters. Similarly, the number of PSTs who used the scaling-up strategy and attended to the proportional relationships in their explanations were two, one, two, and four, for Problems 2, 3, 4, and 5, respectively. Hence, the PSTs who used the scaling-up strategy tended to attend proportional relationships in their explanations.

Regarding to the PSTs' responses on Problems 2, 3, and 4, they generally attended to the equality of the ratios formed between corresponding sides. In their explanations, these PSTs claimed that because the compared figures were similar, the ratio formed by the lengths of corresponding sides needed to be equal. However, these PSTs usually failed to explain what the equality of ratios implied in each problem. Because of the similarity between two geometric figures, equality of the ratios was taken for granted by many of these PSTs. Therefore, the PSTs did not recognize proportional relationships in their explanations. One other finding was that 19 PSTs could not provide correct explanations for their solutions on Problem 5. Fourteen PSTs solved this problem incorrectly and accordingly they provided erroneous explanations. In general, many of the PSTs' explanations were not sufficient enough for us to have a conclusion on their understanding of proportional relationships in the given similarity problems.

Table 4. The preservice teachers' explanations

Items	Attention to the proportional relationships	Attention to the equality of the ratios formed between the lengths of corresponding sides	Repetition of the solution, erroneous explanations, or no response
Problem 1	11	13	8
Problem 2	6	22	4
Problem 3	3	26	3
Problem 4	6	20	6
Problem 5	8	5	19

It was our expectation that providing figures to be compared one within the other (see Problems 3, 4, and 5 in Appendix), in contrast to the traditional approach (see Problem 2 in Appendix), might help PSTs in recognizing the proportional relationships between sides because this method of presentation offers a visually easier comparison of the changes in sizes. During the interview with Canan, the interviewer asked her if the placement of the figures had any effects on her strategy choices, and her response was "No." However, she noted that if she were teaching this topic, she could have used figures that are easy to compare. As seen in Table 4, only a small number of the PSTs explained proportional relationships in Problems 3, 4, and 5, and there was no difference between the numbers of multiplicative explanations provided for Problem 2. This result suggested that the placement of similar figures was inadequate by itself in facilitating the PSTs' recognition of the proportional relationships in geometric similarity problems.

Discussion and Conclusions

The purpose of this study was to examine the solution strategies of PSTs for geometric similarity problems and the effects of problem characteristics (such as problem context and numbers used) on their identification of proportional relationships. For the first research question (i.e., solution strategies), the results showed that the PSTs used a limited number of strategies when solving the geometric similarity problems, and they usually relied on the cross-multiplication strategy in their solutions (Table 2). In this study, we encouraged the PSTs for providing multiple solutions. The analysis indicated that they usually preferred the remaining strategies as their second choices (see Table 3). The results of this study confirm the results from the literature (e.g., Lobato & Ellis, 2010) documenting that students fail to identify proportional relationships in problems involving

similarity, scaling, stretching, or shrinking. One reason for the PSTs' difficulties in identifying proportional relationships appear to be related to their overreliance on the cross-multiplication strategy because this strategy leads to focusing only on numbers instead of making sense of the proportional relationships among quantities. Past research (e.g., Fisher, 1988; Lesh, Post, & Behr, 1988) also supports our finding that the cross-multiplication strategy is the most common strategy that students and teachers use to solve these types of problems. However, as Izsák and Jacobson (2013) argued, reasoning about proportional relationships requires an understanding that goes far beyond the use of the cross-multiplication strategy. Similarly, in the present study, overreliance on the cross-multiplication strategy appeared to constrain the PSTs' understandings of proportional relationships because only a few of them attended to the proportional relationships in their explanations for proportional relationships between the corresponding sides of the similar figures. The second most common strategy after the cross-multiplication strategy was the scaling-up strategy. Because the use of scaling-up strategy enabled the PSTs' recognition of the multiplicative relationships between the lengths of corresponding sides, they tended to attend proportional relationships in their explanations. We found that the PSTs who used the scaling up strategy were more successful in explaining the proportional relationships than the PSTs who used the remaining strategies. Cox (2013) reported that 11 out of 21 middle grades students, in her study, used the scaling-up strategy involving proportional relationships. On the contrary, in our study, the PSTs were found to rely heavily on the cross-multiplication as the dominant strategy, and resorted rarely to the scaling-up strategy. This finding indicates that the instruction in teacher education programs needs to focus not only on developing procedural understanding as shown by the PSTs' overreliance on the cross-multiplication strategy, but also on supporting their conceptual understanding as in their use of the scaling-up strategy.

For the second research question (i.e., effects of problem characteristics on solution strategies and identification of proportional relationships), the results indicated that even though presenting problems in a real-world context matters, placing similar figures side-by-side or one-within-another does not seem to influence PSTs' identification of proportional relationships. Providing problems in a real-world context, such as in Problem 1, seemed to facilitate the PSTs' recognition of the proportional relationships between the sides. For example, while 12 PSTs used the scaling-up strategy to solve the problem in Problem 1 (see Table 2), 10 PSTs attended to proportional relationships in their explanations in this problem (see Table 4). Hence, the use of real-world contexts in geometric similarity problems increased the PSTs' attention to the proportional relationships between corresponding sides of the similar figures.

Moreover, the placement of similar figures as either side-by-side or one-within-another did not seem to have an impact on the PSTs' identification of proportional relationships between the corresponding sides. Although it was initially hypothesized that providing similar figures one-within-another (as in Problems 3, 4, and 5) facilitates the recognition of proportional relationships in geometric similarity problems due to visual comparison of the changes in sizes, in this study, such a placement of figures did not facilitate the PSTs' recognition of proportional relationships in the given test problems. In the traditional instruction on geometric similarity, students are usually provided with two triangles or rectangles. However, Problem 5 required comparison of two similar trapezoids, and many of the PSTs appeared not understand what expanding a smaller trapezoid by a ratio of 2:3 implied. This result suggested the PSTs' difficulties in coordinating the co-variation between the lengths of corresponding sides in two trapezoids and difficulties in understanding the ratio of the corresponding lengths always being in a constant ratio of 2:3. Therefore, we suggest that using geometric figures to which students may not be familiar (including figures with irregular shapes) can help teachers determining students' understanding of geometric similarity and its relationship with proportional relationships.

Overall, the PSTs' overreliance on the cross-multiplication strategy and inability to provide meaningful explanations for their solutions indicated constraints about their understanding of the proportional relationships in the geometric similarity problems. Thus, the results of this study imply that PSTs' main difficulties in geometric similarity problems might be due to instruction based on the traditional approach that mostly relies on rote memorization and isolated procedures such as the cross-multiplication algorithm (Hiebert, 2003). To overcome the constraints discussed in here, as the main implication of this study, we propose a new approach, named the *dilating perspective* approach, which has the potential for instruction to make strong connections between geometric similarity and proportional relationships, in the following section.

The Dilating Perspective and Recommendations for Further Research

As stated by Beckmann and Izsák (2015), geometric similarity is defined in connection with dilations. A dilation is "a transformation that moves each point along the ray through the point emanating from a fixed centre, and multiplies distances from the centre by a common scale factor" (CCSSI, 2010, p.85). According to the CCSSI,

eight graders should use ideas about similarity to define and analyse two-dimensional figures and describe how these figures change under some geometric transformations (i.e., translations, rotations, reflections, and dilations). Hence, Beckmann and Izsák (2015) suggested using the *dilating perspective* approach (known as the Fixed Numbers of Variable Parts Perspective) for developing students’ understanding of geometric similarity from a transformational approach such as through dilations. In the *dilating perspective* approach, “two quantities are said to be in the ratio A to B if for some-sized part there are A parts of the first quantity and B parts of the second quantity” (Beckmann & Izsák, 2015, p. 21). The *dilating perspective* approach, often an overlooked approach, suggests a stretching or shrinking view of continuous covariation in a uniform sense. This approach holds promise for preventing students and teachers’ overreliance on the cross-multiplication strategy without making sense of proportional relationships.

In order to illustrate the *dilating perspective* approach, Figure 6 is provided to indicate uniform stretching and shrinking of a rectangle’s height and width in a fixed 3:4 ratio. As an example solution for Problem 4 using this perspective, one can recognize that there is a 3 to 4 ratio between the lengths of the height and width of rectangle ABCD:

$$\frac{27}{36} = \frac{3}{4}$$

Because of the existence of a fixed 3 to 4 ratio between the lengths of AD and AB, one can also represent these lengths with strip diagrams that have three and four equal parts, respectively (Figure 6). Therefore, each part will have a length of 9 mm. From the *dilating perspective* approach, for some-sized part, which is 9 mm for this specific example, there are 3 parts of the height and 4 parts of the width, where 3 and 4 specify fixed numbers of parts that can vary in size. Because ABCD and EFGH are similar, the 3 to 4 ratio remains invariant in EFGH. Hence, one can also represent EH and HG with two strip diagrams that have three and four equal parts, respectively. The length of EH is given to be 30 mm, so the length of each part is calculated to be $30 \div 3 = 10$ mm. Because HG is represented by four parts, one can calculate its length by multiplying 10 mm by 4, so the length of HG can be calculated to be 40 mm. In Problem 4, corresponding sides of ABCD and EFGH rectangles stretch or shrink uniformly either by a scale factor of $\frac{10}{9}$ or by $\frac{9}{10}$, respectively. Thus, the *dilating perspective* enables students to realize this uniform stretching or shrinking and emphasizes proportional relationships among quantities that vary together.

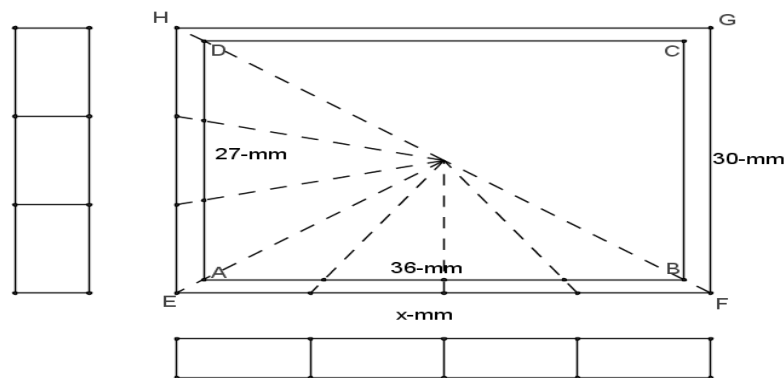

Figure 6. A solution for Problem 4 using the Dilating Perspective approach

Finally, this study makes at least two contributions to the literature. First, it provides strong evidence that PSTs often do not have robust connections between the essential concepts of proportional relationships and geometric similarity. They usually have difficulties in identifying proportional relationships when solving geometric similarity problems, and their solution strategies heavily rely on the cross-multiplication strategy. Second, this study proposes a new approach, *the dilating perspective*, for classroom settings that holds promise for advancing students and teachers’ identification of proportional relationships through its emphasis on quantities that covary.

Further studies should examine the effectiveness of the *dilating perspective* approach in developing PSTs’ identification of proportional relationships when reasoning with geometric similarity. One limitation of this study was the sample size. Having a larger sample size would potentially provide different result in terms of the effects of problem characteristics on PSTs’ solution strategies and identification of proportional relationships. Future studies are needed to examine these effects with larger sample sizes and with different populations. In addition, in this study, the PSTs did not have instruction on the *dilating perspective*. Hence future studies should

examine the effects of the dilating perspective approach on PSTs' understanding of proportional relationships in geometric similarity problems.

References

- Arican, M. (2018). Preservice middle and high school mathematics teachers' strategies when solving proportion problems. *International Journal of Science and Mathematics Education*, 16(2), 315–335. doi:10.1007/s10763-016-9775-1
- Beckmann, S., & Izsák, A. (2015). Two perspectives on proportional relationships: Extending complementary origins of multiplication in terms of quantities. *Journal for Research in Mathematics Education*, 46(1), 17–38. Retrieved from <http://www.jstor.org/stable/10.5951/jresmetheduc.46.1.0017>
- Common Core State Standards Initiative (2010). *The common core state standards for mathematics*. Washington, D.C.: Author. Retrieved from http://www.corestandards.org/assets/CCSSI_Math%20Standards.pdf
- Common Core Standards Writing Team (2011). *Progressions for the Common Core State Standards for Mathematics (draft), 6-7, ratios and proportional relationships*. Retrieved from <http://math.arizona.edu/~ime/progressions/>
- Cox, D. C. (2013). Similarity in middle school mathematics: At the crossroads of geometry and number. *Mathematical Thinking and Learning*, 15(1), 3–23.
- Cox, D. C., Lo, J. J., & Mingus, T. (2007). Low achieving middle school students' conceptions of same shape. In T. Lamberg & L. R. Wiest (Eds.), *Proceedings of the 29th annual meeting of the North American Chapter of the International Group for the Psychology of Mathematics Education* (pp. 130–132). Stateline, NV: University of Nevada, Reno.
- De Bock, D., Verschaffel, L., & Janssens, D. (1998). The predominance of the linear model in secondary school students' solutions of word problems involving length and area of similar plane figures. *Educational Studies in Mathematics*, 35, 65–85. doi:10.1023/A:1003151011999
- DeJarnette, A. F., Walczak, M., & González, G. (2014). Students' concepts- and theorems-in-action on a novel task about similarity. *School Science & Mathematics*, 114(8), 405–414. doi:10.1111/ssm.12092.
- Fisher, L. C. (1988). Strategies used by secondary mathematics teachers to solve proportion problems. *Journal for Research in Mathematics Education*, 19(2), 157–168. Retrieved from <http://www.jstor.org/stable/749409>
- Harel, G., & Behr, M. (1995). Teachers' solutions for multiplicative problems. *Hiroshima Journal of Mathematics Education*, 3, 31–51. Retrieved from http://www.cehd.umn.edu/ci/rationalnumberproject/95_2.html
- Hart, K. (1981). Ratio and proportion. In K. Hart (Ed.), *Children's understanding of mathematics: 11–16* (pp. 88–101). London: John Murray.
- Hart, K. (1984). *Ratio: Children's Strategies and Errors*. A Report of the Strategies and Errors in Secondary Mathematics Project. London: NFER-Nelson.
- Hiebert, J. (2003). What research says about the NCTM standards. In J. Kilpatrick, G. Martin, & D. Schifter (Eds.), *A research companion to principles and standards for school mathematics* (pp. 5–26). Reston, VA: NCTM.
- Izsák, A., & Jacobson, E. (2013, April). *Understanding teachers' inferences of proportionality between quantities that form a constant difference or constant product*. Paper presented at the National Council of Teachers of Mathematics Research Pre-session, Denver, CO.
- Kaput, J., & West, M. (1994). Missing-value proportional reasoning problems: Factors affecting informal reasoning patterns. In G. Harel & J. Confrey (Eds.), *The development of multiplicative reasoning in the learning of mathematics* (pp. 235–287). Albany: State University of New York Press.
- Karplus, R., Pulos, S., & Stage, E. (1983b). Proportional reasoning of early adolescents. In R. Lesh & M. Landau (Eds.), *Acquisition of mathematics concepts and processes* (pp. 45–90). New York, NY: Academic.
- Lamon, S. J. (1993). Ratio and proportion: Connecting content and children's thinking. *Journal for Research in Mathematics Education*, 24(1), 41–61. doi: <http://www.jstor.org/stable/749385>
- Lamon, S. J. (1999). *Teaching fractions and ratios for understanding*. New Jersey: Lawrence Erlbaum.
- Lee, H. S., & Yim, J. (2014). Pursuing coherence among proportionality, linearity, and similarity: Two pathways from preservice teachers' geometric representations. *The Mathematics Enthusiast*, 11(3), 541–554. Retrieved from <http://scholarworks.umt.edu/cgi/viewcontent.cgi?article=1316&context=tme>
- Lehrer, R., Strom D., & Confrey, J. (2002). Grounding metaphors and inscriptional resonance: Children's emerging understanding of mathematical similarity. *Cognition and Instruction*, 20(3), 359–398.

- Lesh, R., Post, T., & Behr, M. (1988). Proportional reasoning. In J. Hiebert & M. Behr (Eds.), *Number concepts and operations in the middle grades* (pp. 93–118). Reston, VA: National Council of Teachers of Mathematics.
- Lester, F. K., Masingila, J. O., Mau, S. T., Lambdin, D. V., dos Santos, V. M. P., & Raymend, A. M. (1994). Learning how to teach via problem solving. In D. B. Aichele & A. F. Coxford (Eds.), *Professional development for teachers of mathematics: 1994 yearbook* (pp. 152–166). Reston, VA: NCTM.
- Lobato, J., & Ellis, A. (2010). *Developing essential understanding of ratios, proportions, and proportional reasoning for teaching mathematics: Grades 6-8*. Reston, VA: National Council of Teachers of Mathematics.
- National Council of Teachers of Mathematics (2000). *Principles and standards for school mathematics*. Reston, VA: Author.
- Olmez, I. B. (2016). Two distinct perspectives on ratios: Additive and multiplicative relationships between quantities. *Elementary Education Online*, 15(1), 186–203. doi: <http://dx.doi.org/10.17051/io.2016.94175>
- Orrill, C. H., & Brown, R. E. (2012). Making sense of double number lines in professional development: Exploring teachers' understandings of proportional relationships. *Journal of Mathematics Teacher Education*, 15(5), 381–403. doi: 10.1007/s10857-012-9218-z
- Van den Brink, J., & Streefland, L. (1979). Young children (6–8)—Ratio and proportion. *Educational Studies in Mathematics*, 10(4), 403–420.
- Vergnaud, G. (1983). Multiplicative structures. In R. Lesh & M. Landau (Eds.), *Acquisition of mathematics concepts and processes* (pp. 127–174). Orlando, FL: Academic Press.
- Vergnaud, G. (1988). Multiplicative structures. In J. Hiebert & M. Behr (Eds.), *Number concepts and operations in middle grades* (pp. 141–161). Reston, VA: National Council of Teachers of Mathematics.

Author Information

Muhammet Arican

Ahi Evran University
 Assistant Professor of Mathematics Education
 Kirsehir / Turkey
 Contact e-mail: muhammetarican@gmail.com

Oguz Koklu

Marmara University
 Atatürk Faculty of Education
 Teaching Assistant Dr. of Mathematics Education
 Istanbul / Turkey

Ibrahim Burak Olmez

University of Georgia
 Research Assistant of Mathematics Education
 Athens / The United States of America

Serdal Baltaci

Ahi Evran University
 Assistant Professor of Mathematics Education
 Kirsehir / Turkey

Appendix

Geometric Similarity Test

Problem 1: During a particular time of a day, the shadow of a 4-meter tree was measured to be 1.5 meters. At the same time, the shadow of an apartment was measured to be 7.5 meters. Please calculate the height of this apartment.

Problem 2: In the figure below, two similar rectangles, ABCD and EFGH, are given. Please calculate the length of EF considering the information provided about the lengths of the sides.

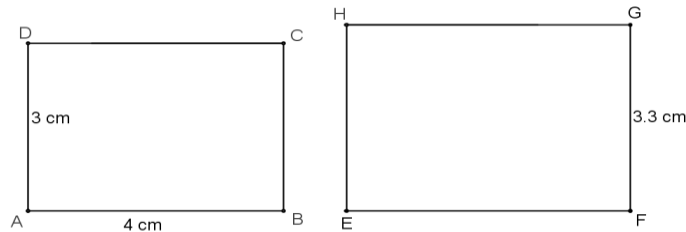

Problem 3: In the figure below, two similar rectangles, ABCD and AFGH, are given. Please calculate the length of CD considering the information provided about the lengths of the sides.

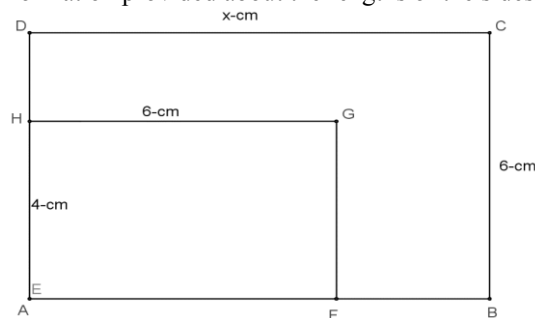

Problem 4: In the figure below, two similar rectangles, ABCD and EFGH, are given. Please calculate the length of EF considering the information provided about the lengths of the sides.

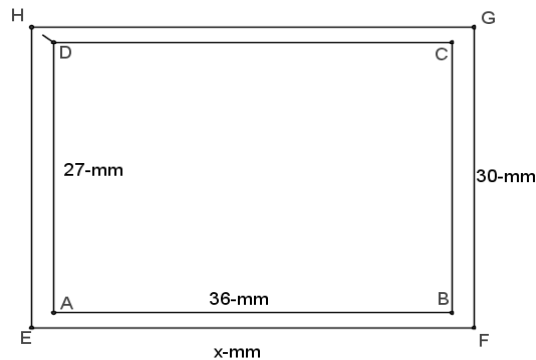

Problem 5: In the figure below, two similar isosceles trapezoids, ABCD and EFGH, are given. The EFGH trapezoid is formed from the ABCD trapezoid by dilating the sides in a ratio of 2:3. If the length of AB is measured to be 5 cm, please calculate the length of EF.

